

2026

MDA KATALOG





ZAŠTO IZBRATI **FUEGO?**

U kompaniji Fuego vjerujemo da veliki kućanski aparati treba da pruže savršenu ravnotežu između **tehnologije, pouzdanosti i savremenog dizajna**. Naša MDA rješenja stvorena su da unaprijede svakodnevni život uz pametne funkcije, snažne performanse i dugotrajnu izdržljivost.

Svaki proizvod prolazi stroga testiranja kvaliteta kako bi se garantovali dosljedni rezultati i pouzdana efikasnost, osiguravajući da vaš dom funkcioniše glatko i bez napora. Uz snažan fokus na inovacije za uštedu energije i savremeni inženjering, Fuego MDA aparati su napravljeni da rade tiho, efikasno i ekonomično, bez kompromisa.

Kombinujemo **moderanu estetiku sa praktičnom funkcionalnošću**, dizajnirajući aparate koji se besprijekorno uklapaju u svaku kuhinju ili kućno okruženje. Od preciznog kuhanja do jednostavnog čišćenja i optimalnog čuvanja hrane, Fuego nudi rješenja koja čine da svako domaćinstvo funkcioniše pametnije i efikasnije.







MAŠINE ZA PRANJE SUĐA

Fuego mašine za pranje posuđa pružaju besprijekorno čišćenje uz minimalan napor zahvaljujući naprednim programima pranja i optimizovanim ciklusima potrošnje vode. Dizajnirane za tih rad i energetska efikasnost, osiguravaju odlične performanse pri svakom pranju. Dostupne su u samostojećim i ugradnim verzijama, te se savršeno uklapaju u svaki raspored kuhinje.

PRANJE SUĐA



NAZIV MODELA	DWFGMTT 500621 W	DWFGMFS 450622 W	DWFGSW 6092 FSW
	DWFGMTT 500621 S	DWFGMFS 450622 SI	DWFGSW 6092 FSIX
ENERGETSKA EFIKASNOST	A+	A++	E
KAPACITET	6 SETOVA	9 SETOVA	13 SETOVA
DIMENZIJE	55x43.8x50cm	84.5 x 44.8 x 60cm	598*598*845 mm
ODGODA STARTA	1-24h	1-24h	1-24h
PROGRAMI	7	6	9
LED DISPLEJ	✓	✓	✓
DJEČIJA ZAŠTITA	✓	✓	✓
POTROŠNJA ENERGIJE KWH / 100	61kWh	70kWh	✗
NIVO BUKE	49dB	49dB	49dB
POTROŠNJA VODE PO CIKLUSU	6.5L	9L	✗
SERTIFIKATI	CE/ROSH	CE/ROSH	CE/CB/ERP/RoHS/REACH/GS



NAZIV MODELA	DWFGSW 6083 FSIX
ENERGETSKA EFIKASNOST	B
KAPACITET	15 SETOVA
DIMENZIJE	598*598*845 mm
DVOSTRUKO PRANJE	✓
PROGRAMI	8
LED DISPLEJ U BOJI	✓
SUŠENJE TOPLIM ZRAKOM	✓
AUTOMATSKA VRATA	✓
NIVO BUKE	46dB
MOTOR	BLDC
SERTIFIKATI	CE/CB/ERP/ROHS/REACH/GS





NAZIV MODELA	DWFGSW 45102 BIE	DWFGSW 4583 BI
ENERGETSKA EFIKASNOST	E	B
KAPACITET	10 SETOVA	10 SETOVA
DIMENZIJE	448*555*815 mm	448*555*815 mm
PROGRAMI	8	8
LED DISPLEJ U BOJI	✗	✓
SUŠENJE NA TOPLOM ZRAKU	STEPEN RASPRŠIVAČA: TOP + UPPER + LOWER	STEPEN RASPRŠIVAČA: TOP + UPPER + LOWER
NIVO BUKE	53dB	49dB
MOTOR	AC	AC
SERTIFIKATI	CE/CB/ERP/ROHS/REACH/GS	CE/CB/ERP/RoHS/REACH/GS

PRANJE SUĐA



NAZIV MODELA	DWFGSW 60138 BI	DWFGSW 6083 BI
ENERGETSKA EFIKASNOST	E	B
KAPACITET	13 SETOVA	15 SETOVA
DIMENZIJE	600*560*815mm	600*560*815 mm
MOTOR	AC	BLDC
PROGRAMI	8	8
KONTROLNI PANEL	GORNJA KONTROLA+5 MEHANIČKIH DUGMADI	GORNJA KONTROLA+15 MEHANIČKIH DUGMADI
NIVO RASPRŠIVANJA	GORNJI + SREDNJI + DONJI GRIJAČ	GORNJI + SREDNJI + DONJI GRIJAČ
NIVO BUKE	53dB	49dB
SERTIFIKATI	CE/CB/ERP/ROHS/REACH/GS	CE/CB/ERP/ROHS/REACH/GS

- AUTOMATSKA VRATA
- UV HIGIJENA
- SUŠENJE TOPLIM ZRAKOM
- DVOSTRUKO PRANJE



MDA KUHANJE

FUEGO KUHANJE nudi preciznu kontrolu, brzo zagrijavanje i inovativnu tehnologiju osmišljenu da pojednostavi svaki kulinarski zadatak. Naše nape, ploče za kuhanje, mikrovalne pećnice, rerne i šporeti pružaju izvanrednu funkcionalnost i savremenu praktičnost. Svaki proizvod kombinuje energetska efikasnost sa elegantnim, modernim dizajnom koji odgovara potrebama savremenih domova.

- Nape (aspirator)
- Ploče za kuhanje
- Mikrovalne pećnice
- Rerne
- Šporeti

MDA KUHANJE



1 FUEGO NAPE pružaju snažno, ali tiho izvlačenje zraka, osiguravajući čisto i svježije okruženje za kuhanje. Elegantnim dizajnom i pouzdanim sistemima filtracije unapređuju i performanse i estetiku kuhinje.



HDFGTM 52350 BIIX-INOX

NAZIV MODELA	HDFGTM 52350 BIB	HFGTM60TBIX
SNAGA USISAVANJA	350m ³ /hr	345m ³ /hr
BRZINA	3-TIPKE ZA PODEŠAVANJE BRZINE	2- PREKIDAČ ZA PODEŠAVANJE BRZINE
DIMENZIJE	525*291*133mm	595*300*161mm
FILTER	3 VIŠESLOJNI ALUMINIJSKI FILTER	3 VIŠESLOJNI ALUMINIJSKI FILTER
KARBON FILTER	CF150- 1 FILTER	CF150- 2 FILTERA
IZLAZ ZRAKA	Φ=150mm	Φ=120mm
LED SVJETLA	2x1.5w	1x2w
MOTOR	1x65w	2x80w
SERTIFIKATI	CE LVD CE EMC	CE LVD CE EMC
	52CM ŠIROKA UGRADNA NAPA INOX LAKIRANI PANEL + POCINČANI ČELIK	60CM ŠIROKA IZVLAČNA NAPA PANEL OD #430 NEHRĐAJUĆEG ČELIKA + POCINČANA KAPA



NAZIV MODELA	HFGTM60TBIB
SNAGA USISAVANJA	345m ³ /hr
BRZINA	2-TIPKE ZA PODEŠAVANJE BRZINE
DIMENZIJE	595*300*161mm
FILTER	3 VIŠESLOJNI ALUMINIJSKI FILTER
KARBON FILTER	CF150- 2 FILTERA
IZLAZ ZRAKA	Φ=120mm
LED SVJETLA	1x2w
MOTOR	2x80w
SERTIFIKATI	CE LVD CE EMC
	ŠIROKA IZVLAČNA NAPA PANEL OD #430 NEHRĐAJUĆEG ČELIKA U CRNOJ BOJI + POCINČANA KAPA



NAZIV MODELA	CHFGTM75PB	CHFGTM60DGB
SNAGA USISAVANJA	750m ³ /hr	500m ³ /hr
BRZINA	3-TIPKE ZA BRZINU	КОПЧЕ СО 3 БРЗИНИ
DIMENZIJE	745*500*295mm	595*329*305mm
FILTER	5 SLOJNI ALUMINIJUMSKI FILTER	3 SLOJNI ALUMINIJUMSKI FILTER
IZLAZ ZRAKA	Φ=150mm	Φ=150mm sa cijevi od 2 m
LED SVJETLA	1x2w	2x1.5w
MOTOR	1x230w	1x65w
SERTIFIKATI	CE LVD CE EMC	CE LVD CE EMC
	CRNO LAKIRANO KUĆIŠTE	CRNO LAKIRANO KUĆIŠTE + STAKLENI PANEL

• ODŽAK: 2x400mm



MODEL	CHFGTM60DGBX
SNAGA USISAVANJA	350m ³ /hr
PREKIDAČ	PREKIDAČ NA DODIR
DIMENZIJE	595*386*379mm
FILTER	5 SLOJNI ALUMINIJUMSKI FILTER
ODŽAK	2x400mm
IZLAZ ZRAKA	Φ=150mm sa cijevi od 2 m
LED SVJETLA	2x1.5w
MOTOR	1x65w
SERTIFIKATI	CE LVD CE EMC

• CRNO LAKIRANO KUĆIŠTE + STAKLENI PANEL



NAZIV MODELA	CHF60DGB-R
SNAGA USISAVANJA	750m ³ /hr
PREKIDAČ	PREKIDAČ NA DODIR
DIMENZIJE	595*386*379mm
FILTER	5 SLOJNI ALUMINIJUMSKI FILTER
ODŽAK	2x400mm
IZLAZ ZRAKA	Φ=150mm sa cijevi od 2 m
LED SVJETLA	2x1.5w
MOTOR	1x230w
SERTIFIKATI	CE LVD CE EMC

- CRNO LAKIRANO KUČIŠTE + STAKLENI PANEL
- AUTOMATSKO OTVARANJE SA DALJINSKIM UPRAVLJAČEM



NAZIV MODELA	CHF90DGB
SNAGA USISAVANJA	750m ³ /hr
DUGME	3 TIPKE ZA BRZINU
DIMENZIJE	895*385*370mm
FILTER	5 SLOJNI ALUMINIJUMSKI FILTER
ODŽAK	2x400mm
IZLAZ ZRAKA	Φ=150mm sa cijevi od 2 m
LED SVJETLA	2x1.5w
MOTOR	1x230w
SERTIFIKATI	CE LVD CE EMC

- CRNO LAKIRANO KUČIŠTE + STAKLENI PANEL

2 FUEGO PLOČE ZA KUHANJE

Naše ploče za kuhanje nude brzo zagrijavanje, stabilnu kontrolu temperature i siguran rad. Dostupne su u keramičkim, indukcijskim i plinskim izvedbama, pružajući korisnicima potpunu fleksibilnost u načinu kuhanja.



MDA KUHANJE



FUEGO PLOČE ZA KUHANJE

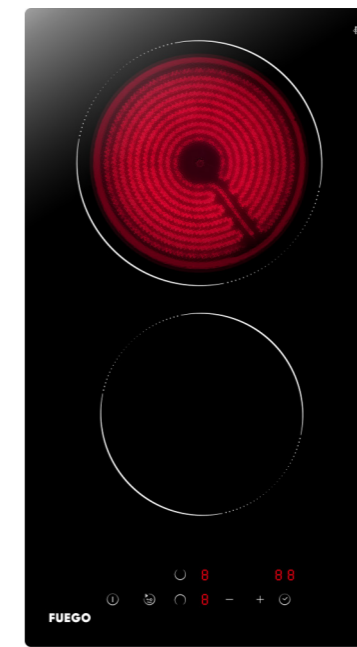

NAZIV MODELA	HBFGE 30302T	HBFGE 30352TI
SNAGA	3000W	3500W
PREDNJA LIJEVA ZONA	1200w / 165mm	1500w; BOOST 1800w / 160mm
STRAŽNJA LIJEVA ZONA	1800w / 200mm	1800w; BOOST 2200w / 180mm
STAKLO	KANGER VITRO KERAMIČKO STAKLO	KANGER STAKLO
NIVO SNAGE	9	9
TAJMER	99	99
DIMENZIJA	288*520*51mm	288*520*61 mm
SERTIFIKATI	CE LVD CE EMC	CE LVD CE EMC
NETO TEŽINA	4KG	4KG
DUŽINA KABLA (M)	3*1.5mm2 kabl napajanja, dužina 1m	2*1.5mm2 kabl napajanja dužina 1m
AUTOMATSKO ISKLJUČIVANJE	✓	✓
ZAŠTITA OD PREGRIJAVANJA	✓	✓
DJEČIJA ZAŠTITA	✓	✓
INDIKATOR PREOSTALE TOPLOTE	✓	✓
ZAŠTITA OD PRELIJEVA	✓	✓

FUEGO PLOČE ZA KUHANJE



NAZIV MODELA	HBFGPE 60604T	HBFGPE 60573T
SNAGA	6000W	5700W
PREDNJA LIJEVA ZONA	1800w/ 200mm	1800w / 200mm
STRAŽNJA LIJEVA ZONA	1200w / 165mm	1200w / 165mm
STRAŽNJA DESNA ZONA	1800w / 200mm	2700/1950/1050)w / (300/228/150)mm
PREDNJA DESNA STRANA	1200w / 165mm	✕
STAKLO	KANGER STAKLO	KANGER STAKLO
STEPEN SNAGE	9	9
DIMENZIJA	590*520*51 mm	590*520*51mm
SERTIFIKATI	CE LVD CE EMC	CE LVD CE EMC
NETO TEŽINA	8KG	9KG
DUŽINA KABLA (M)	5*1.5mm2 dužina kabla napajanja 1m	5*1.5mm2 power cable length 1m
AUTOMATSKO ISKLJUČIVANJE	✓	✓
ZAŠTITA OD PREGRIJAVANJA	✓	✓
DJEČIJA ZAŠTITA	✓	✓
INDIKATOR PREOSTALE TOPLOTE	✓	✓

FUEGO PLOČE ZA KUHANJE



NAZIV MODELA	HBFGPE 606642TS	HBFGPE 6070B2TS
SNAGA	6600W	7000W
PREDNJA LIJEVA ZONA	2200/1000w / 230/150mm	2000 / BOOST 2300)w / 200mm
STRAŽNJA LIJEVA ZONA	1200w / 165mm	1500w / BOOST 1900)w / 200mm
STRAŽNJA DESNA STRANA	2000/1100 w / 270/165mm	2000 / BOOST 2300)w / 200mm
PREDNJA DESNA STRANA	1200w / 165mm	1500w / BOOST 1900)w / 165mm
STAKLO	KANGER VITRO KERAMIČKO STAKLO	KANGER STAKLO
STEPEN SNAGE	9	9
DIMENZIJA	590*520*51mm	590*520*51mm
SERTIFIKATI	CE LVD CE EMC	CE LVD CE EMC
NETO TEŽINA	9KG	9KG
DUŽINA KABLA (M)	3*1.5mm2 kabl napajanja, dužina 1m	2*1.5mm2 kabl napajanja dužina 1m
AUTOMATSKO ISKLJUČIVANJE	✓	✓
ZAŠTITA OD PREGRIJAVANJA	✓	✓
DJEČIJA ZAŠTITA	✓	✓
INDIKATOR PREOSTALE TOPLOTE	✓	✓



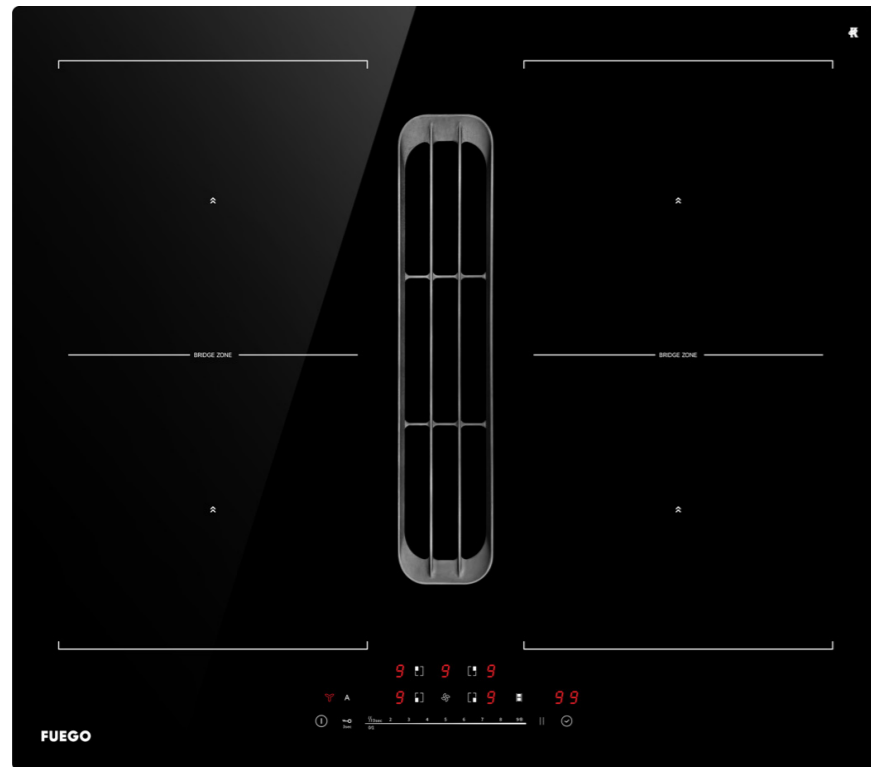

NAZIV MODELA	HBFGPE 60722BIH
SNAGA	7200W
PREDNJI LIJEVI ELEMENAT	2000 / BOOST 2300)w / 200mm
ZADNJI LIJEVI ELEMENAT	1600w / BOOST 1900w / 200mm
STRAŽNJA DESNA ZONA	2000 / BOOST 2300)w / 200mm
PREDNJA DESNA ZONA	1600w / BOOST 1900)w / 200mm
DIMENZIJE SPOJNE ZONE	2800 / BOOST 3600)w 210*400mm
STAKLO	KANGER STAKLO
STEPEN SNAGE	18
DIMENZIJA	590*520*239 mm
SERTIFIKATI	CE / CB / ROHS / ERP
NETO TEŽINA	19.5KG
DUŽINA KABLA (M)	5*1.5mm2 kabla napajanja dužina 1m
PAUZA STOP & GO FUNKCIJA	✓
AUTOMATSKO POVEZIVANJE PLOČE ZA KUHANJE I NAPE	✓
NIVO SNAGE NAPE	9
NIVO BUKE	54dB
ULAZNA SNAGA	110w DC
PROTOK ZRAKA- KROZ KANAL	650m ³

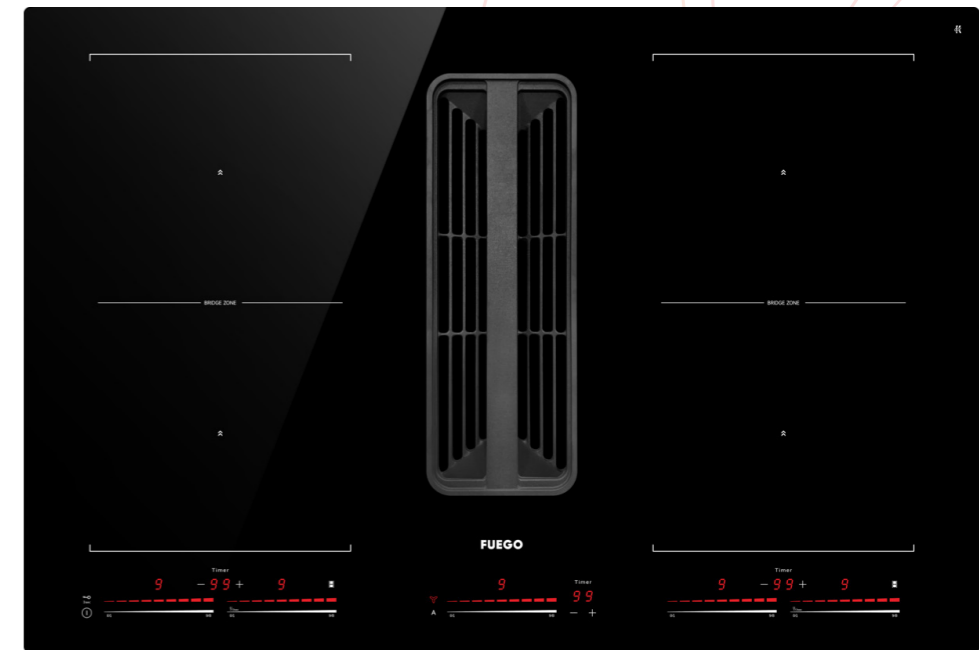

NAZIV MODELA	HBFGPE 77722BIH
SNAGA	7200W
PREDNJI LIJEVI ELEMENAT	2000 / BOOST 2300)w / 200mm
ZADNJI LIJEVI ELEMENAT	1600w / BOOST 1900w / 200mm
STRAŽNJA DESNA ZONA	2000 / BOOST 2300)w / 200mm
PREDNJA DESNA ZONA	1600w / BOOST 1900)w / 200mm
DIMENZIJE SPOJNE ZONE	2800 / BOOST 3600)w 210*400mm
STAKLO	KANGER STAKLO
STEPEN SNAGE	18
DIMENZIJA	770*520*239 mm
SERTIFIKATI	CE / CB / ROHS / ERP
NETO TEŽINA	22.3KG
DUŽINA KABLA (M)	5*1.5mm2 kabl napajanja snage 1m
PAUZA STOP & GO FUNKCIJA	✓
AUTOMATSKO POVEZIVANJE PLOČE ZA KUHANJE I NAPE	✓
NIVO SNAGE NAPE	9
NIVO BUKE	54dB
ULAZNA SNAGA	110w DC
PROTOK ZRAKA- KROZ KANAL	650m ³

3 FUEGO MIKROVALNA

Fuego mikrovalne pećnice omogućavaju brzo zagrijavanje, ravnomjerno kuhanje i jednostavne programe za korištenje. Dostupne u samostojećim i ugradnim izvedbama, prilagođavaju se svakom kuhinjskom prostoru i načinu života.



MDA KUHANJE

MIKROVALNA



NAZIV MODELA	MWFGWE 208W	MWFGWE 208S	MWFGWE 258GB
KAPACITET	20L	20L	25L
IZLAZ / ULAZ	700W / 1100W	700W / 1100W	800W/1280W GRILL 1000W
NIVO SNAGE	10	10	5
MENI	8	8	8
TAJMER	60 MINUTA	60 MINUTA	99 MINUTA
NETO TEŽINA	10.6KG	10.6KG	12.5KG
DISPLEJ	BIJELA	SREBRNA	BIJELA
BOJA UNUTRAŠNJOSTI	SIVA	SIVA	BIJELI / SIVI PREMAZ
OKRETAJUĆE	255mm	255mm	285mm
STAKLENA VRATA	OBIČNO STAKLO S CRNIM SITOTISKOM	OBIČNO STAKLO S CRNIM SITOTISKOM	OBIČNO STAKLO S CRNIM SITOTISKOM
SERTIFIKATI	CE / LVD / EMC / ERP	CE / LVD / EMC / ERP	CE / LVD / EMC / ERP
VELIČINA UNUTRAŠNJOSTI	W301.5*D302*H208.5 MM	W301.5*D302*H208.5 mm	W316.5*D331.5*H235.5mm
VELIČINA PROIZVODA	W456*D326*H263MM	W456*D326*H263MM	W480*D382*H292.5mm
NAČINI KONTROLE			MEMBRANA



NAZIV MODELA	MWFGWE 20GBBI	MWFGWE 25GBBI
KAPACITET	20L	25L
IZLAZ / ULAZ	700W/1100W GRILL: 1000W	900W/1450W GRILL: 1200W
NAČINI UPRAVLJANJA	DIGITALNO	KONTROLA DODIRA, STAKLO TFT
NIVOI SNAGE	5	5
MENI	NE	8
TAJMER	60 MINUTA	60 MINUTA
DISPLEJ	BIJELA	U BOJI
BOJA UNUTRAŠNJOSTI	KERAMIČKI PRAH	SIVA
ROTIRAJUĆI TANJIR	255mm	255mm
STAKLENA VRATA	CRNO OGLEDALO	CRNO OGLEDALO
SERTIFIKATI	CE / LVD / EMC / ERP	CE / LVD / EMC / ERP
VELIČINA UNUTRAŠNJOSTI	W301.5*D302*H219mm	W347*D346.5*H225mm
VELIČINA PROIZVODA	W595*D326*H385mm	W595*D389*H387mm

4 FUEGO RERNE osiguravaju precizne i ujednačene rezultate pečenja zahvaljujući višestrukim načinima kuhanja i ravnomjernoj raspodjeli topline. Dizajnirane za vrhunske performanse i moderan stil, čine kuhanje jednostavnim i pouzdanim.



MDA KUHANJE

FUEGO RERNE



NAZIV MODELA	OVFGAT 734MC	OVFGAT 736TD
FUNKCIJE	4	6
VRATA	CRNO KALJENO STAKLO, TROSTRUKO OSTAKLJENA UKLONJIVA VRATA	CRNO KALJENO STAKLO, TROSTRUKO OSTAKLJENA UKLONJIVA VRATA
KONTROLNI PANEL	CRNO KALJENO STAKLO	CRNO KALJENO STAKLO
UPRAVLJAČKI GUMB	CRNI GUMB	PRITISNI POVUCI GUMB
KLASA ENERGETSKE EFIKASNOSTI	A	A
NETO KAPACITET RERNE	73 litara	73 litara
RUČKA	CRNA RUČKA	S.S RUČKA
TAJMER	MEHANIČKA	LED PROGRAMABILNI SAT
KONTINUIRANA TEMPERATURA	od 50 °C do 250 °C	od 50 °C do 275 °C
SERTIFIKATI	CE / LVD / EMC / ERP	CE / LVD / EMC / ERP
DODACI	PLEH ZA RERNU *1, REŠETKA ZA RERNU *1, BOČNE POLICE *2	PLEH ZA RERNU *1, REŠETKA ZA RERNU *1, BOČNE POLICE *2
	×	POMOĆNA PARA

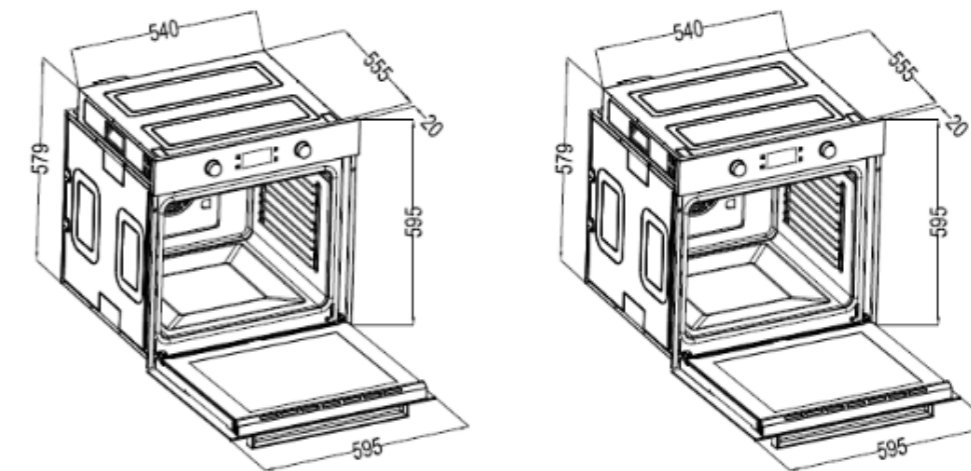

FUEGO RERNA



NAZIV MODELA	OVFGAT 739TDAS	OVFGAT 7312TDSC
FUNKCIJE	9	10
STAKLENA VRATA	CRNO KALJENO STAKLO	CRNO KALJENO STAKLO
KONTROLNI PANEL	CRNO STAKLO & RASTOJANJE POMEĀU KOPČIĀATA & BEL INDIKATOR	BIJELI INDIKATOR -LAK DODIR I ODABIR PROGRAMA
UPRAVLJAČKO DUGME	CRNO STAKLO I VEĆI RAZMAK IZMEĀU DUGMADI I BIJELI INDIKATOR	STAR SIVA DUGMAD
KLASA ENERGETSKE EFIKASNOSTI	A+	A
NETO ZAPREMINA RERNE	73 litra	73 litra
RUČKA	CRNA RUČKA	STAR SIVA I ŠUPLJA RUČKA
TAJMER	LED PROGRAMABILNI SAT / TAJMER	LED PROGRAMABILNI SAT / TAJMER
KONTINUIRANO PODEŠAVANJE TEMP.	од 50 °C до 250 °C	од 50 °C до 250 °C
VRATA	TROSTRUKO ZASTAKLJENA SKIDIVA VRATA	TROSTRUKO ZASTAKLJENA SKIDIVA VRATA
CERTIFIKATI	CE / LVD / EMC / ERP	CE / LVD / EMC / ERP
DODATNA OPREMA	PLEH ZA RERNU *1, REŠETKA ZA RERNU *1, BOČNA POLICA*2	PLEH ZA RERNU *1, REŠETKA ZA RERNU *1 BOČNA POLICA*2 KORPA ZA PEĆENJE*1 KATALITIČKA OBLOGA*2

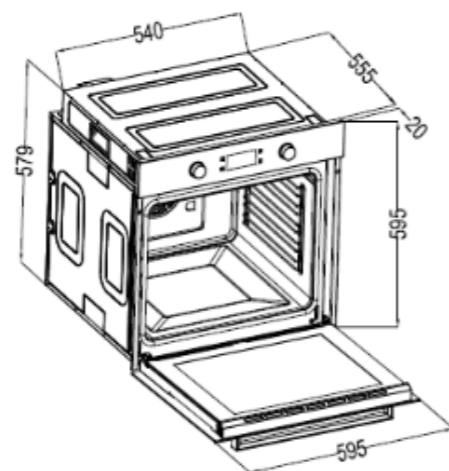

Naši šporeti pružaju potpuno rješenje za kuhanje, kombinujući svestranost, jednostavnost korištenja i pouzdane performanse. Dizajnirani su za svakodnevnu praktičnost bez kompromisa u kvalitetu.



FUEGO ŠPORET

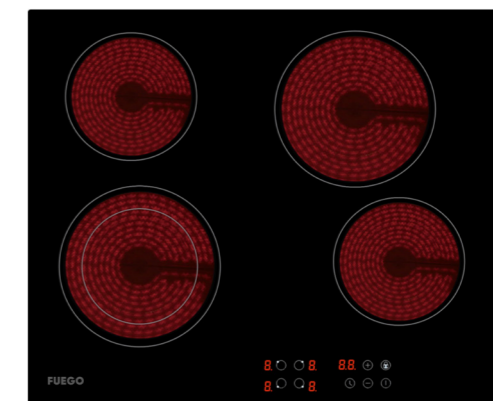

NAZIV MODELA	OVFGAT 73641TD
FUNKCIJE	6
STAKLENA VRATA	CRNO KALJENO STAKLO
KONTROLNI PANEL	CRNI PANEL OD KALJENOG STAKLA
DUGME	UVLAČNO IZVLAČNO DUGME
KLASA ENERGETSKE EFIKASNOSTI	A
NETO ZAPREMINA RERNE	73 litra
RUČKA	S.S RUČKA
TAJMER	LED PROGRAMABILNI SAT / TAJMER
KONTINUIRANO PODEŠAVANJE TEMP.	од 50 °C до 275 °C
VRATA	TROSTRUKO ZASTAKLJENA SKIDIVA VRATA
CERTIFIKATI	CE / LVD / EMC / ERP
DODATNA OPREMA	PLEH ZA RERNU *1, REŠETKA ZA RERNU *1, BOČNA POLICA *2
PLOČA ZA KUHANJE	UKUPNA SNAGA PLOČE ZA KUHANJE: 6400W PREDNJA LIJVEA ZONA: 230mm / 2200W ZADNJA LIJVEA ZONA: 165mm / 1200W ZADNJA DESNA ZONA: 200mm / 1800W PREDNJA DESNA ZONA: 165mm / 1200W

PRANJE I SUŠENJE VEŠA

Fuego uređaji za veš pružaju maksimalnu efikasnost, nizak nivo buke i vrhunsku njegu tkanina. Mašine za pranje veša imaju prilagođene programe za svaku vrstu materijala, dok sušilice osiguravaju brzo i nježno sušenje. 2-u-1 kombinovane mašine za pranje i sušenje veša nude rješenje koje štedi prostor bez žrtvovanja performansi, što ih čini idealnim za moderna domaćinstva.



PRANJE



NAZIV MODELA	WMFGTC 61016 W	7KG WMFGTC 71216 W 8KG WMFGTC 81216 W 9KG WMFGTC 91416 W	8KG WMFGTC 84611 WCD 9KG WMFGTC 94611 WCD
ENERGETSKA EFIKASNOST	A+++	A+++	A+++
CAPACITET	6KG	7 / 8 / 9KG	8 / 9KG
RPM	1000	1200 / 1200 / 1400	1400
NAZIVNA SNAGA	1850W	3A 7 & 8KG 1850W 3A 9KG 1900W	3A 8KG IS 1850W 9KG IS 1900W
POTROŠNJA ENERGIJE	153KW / GOD.	7KG - 174KW GOD. 8KG - 194KW GOD.. 9KG -216KW GOD.	8KG - 194KW GOD. 3A 9KG -216KW GOD.
POTROŠNJA VODE	9680L / GOD.	7KG - 10780L / GOD. 8KG - 11220L / GOD. 9KG - 11880L / GOD.	8KG - 11220L / GOD. 9KG - 11880L / GOD.
TIP EKRANA	LED	LED	LED
MOTOR	UNIVERSAL	BLDC	BLDC
ODGODA	DA	DA	DA
BRZINA	0-400-600-800-1000 RPM	7&8KG: 0-400-600-800-1000-1200) / 9KG: 0-400-600-800-1000- 1200-1400 RPM	0-400-600-800-1200-1400 RPM
TEMPERATURA	HLADNO:20-30-40-60-95°C	HLADNO :20-30-40-60-95°C	HLADNO:20-30-40-60- 95°C
NIVO BUKE	PRANJE 62DBCENTR. 76DB	PRANJE 62DB ; CENTR.	PRANJE 62DB ; CENTR. 76DB
DIMENZIJE PROIZVODA	600*450*850mm	7KG: 595*495*850 8KG: 600*520*850 9KG: 595*560*850	8KG: 595*560*850 9KG: 595*620*850
NETO TEŽINA	50KG	7KG: 57KG 8KG: 55KG 9KG: 64KG	8KG: 55KG 9KG: 64KG
PROGRAM PRANJA	Mješovito; Super brzo; Vuna; Košulje; Sportska odjeća; Intenzivno; Posteljina; Antialergijski program; Pamuk; Predpranje; ECO 40-60; 20°C; Osjetljivo; Čišćenje bubnja; Centrifuga; Ispiranje + centrifuga	Mješovito; Super brzo; Vuna; Košulje; Sportska odjeća; Intenzivno; Posteljina; Antialergijska njega; Pamuk; +Predpranje; ECO 40-60; 20°C; Osjetljivo; Čišćenje bubnja; Centrifuga; Ispiranje + centrifuga	Mješovito; Super brzo; Vuna; Košulje; Sportska odjeća; Intenzivno; Posteljina; Antialergijska njega; Pamuk; +Predpranje; ECO 40-60; 20°C; Osjetljivo; Čišćenje bubnja; Centrifuga; Ispiranje + centrifuga
PROMJER VRATA	308mm	310mm	308mm
CERTIFFIKATI	CE / LVD / EMC / ERP	CE / LVD / EMC / ERP	CE / CB /ERP

PRANJE I SUŠENJE VEŠA



NAZIV MODELA	8KG WMFGTC81216DD SIVA 8KG WMFGTC 81216 DDW BJELA	WMFGTC 101216W	WMFGTC 9121DD
ENERGETSKA EFIKASNOST	A+++	A+++	A-25%
KAPACITET	8KG	10KG	9KG
RPM	1200	1200	1200
POTROŠNJA ENERGIJE	194KW / GOD.	237KW / GOD.	0.87KW/ / ZA CIKLUS
TIP EKRANA	LED DUGME	LED	DODIR U BOJI
MOTOR	DD	BLDC	DD
ODGODA	DA	DA	DA
BRZINA	0-400-800-1200 RPM	0-400-600-800-1200-1400 RPM	0-400-600-800-1200-1400 RPM
TEMPERATURA	HLADNO:30-40-60-90°C	HLADNO:20-30-40-60-95°C	HLADNO:20-30-40-60-95°C
NIVO BUKE	PRANJE 62DB ; CENTR. 76DB	PRANJE 58DB ; SPIN 72DB	PRANJE 58DB ; SPIN 72DB
DIMENZIJE PRODUKTA	8KG: 595*560*850 NETO TEŽINA: 65KG	10KG: 600*561*850 NETO TEŽINA: 66KG	9KG: 600*520*850) NETO TEŽINA: 66KG
NETO TEŽINA	50KG	7KG: 57KG 8KG: 55KG 9KG: 64KG	66KG
PROGRAM PRANJA	MJEŠOVITO; SUPER BRZO; VUNA; KOŠULJE; SPORTSKA ODJEĆA; INTENZIVNO; POSTELJINA; ANTIALERGIJSKI PROGRAM; PAMUK; +PREDPRANJE; EKO 40-60; 20°C; OSJETLJIVO; ČIŠĆENJE BUBNJA; CENTRIFUGA; ISPIRANJE + CENTRIFUGA	MJEŠOVITO; SUPER BRZO; VUNA; POSTELJINA; ANTIALERGIJSKI PROGRAM; PAMUK; OSJETLJIVO; ČIŠĆENJE BUBNJA; CENTRIFUGA; ISPIRANJE + CENTRIFUGA	MJEŠOVITO, BRZO PRANJE, PAMUK, POSTELJINA, DJEČIJA ODJEĆA, PERJE, VUNA, SVILA, OBOJENA ODJEĆA, ANTIALERGIJSKA NJEGA, ISPIRANJE + CENTRIFUGA, CENTRIFUGA, ČIŠĆENJE BUBNJA, PROTOČNO ISPIRANJE, AKTIVNA SVJEŽINA, BRZO UKLANJANJE MRLJA PRO
ZAPREMINA UNUTRAŠNJEG BUBNJA	8KG-49L	10KG-63L	9KG-63L
DIJAMETAR VRATA	320mm	360mm	360mm
CERTIFIKATI	CE /CB /ERP	CE /CB / B / EMC / ERP	CE /CB / B / EMC / ERP

MAŠINI ZA SUŠENJE



NAZIV MODELA	DRFGTC80HP	DRFGTC 815WCD	
ENERGETSKA EFIKASNOST	A+	A++	E
KAPACITET	8KG	8KG	8KG
NAZIVNA SNAGA	570W	800W	570W
ZAPREMINA UNUTRAŠNJEG BUBNJA	102L	102L	102L
TIP DISPLEJA	LED	LED	DODIR U BOJI
MOTOR	STANDARD	STANDARD	INVERTER
ODGODA	DA	DA	DA
NIVO BUKE	PRANJE 69DB	PRANJE 66DB	PRANJE 66DB
DIMENZIJE PROIZVODA	600*584*853mm	600*584*853mm	600*520*853mm
NETO TEŽINA	43KG	43KG	43KG
MATERIJAL BUBNJA	×	×	STAINLESS STILL
PROGRAM PRANJA	MJEŠOVITO; BRZO 30°C; OSJETLJIVO; KOŠULJE; PEŠKIRI; POSTELJINA; NJEGA BEBE; OSVJEŽAVANJE; PAMUK; DONJI VEŠ; PERJE; SINTETIKA; SPORTSKA ODJEĆA; FARMERKE; OUTDOOR+	MJEŠOVITO; BRZO 30°C; OSJETLJIVO; KOŠULJE; PEŠKIRI; POSTELJINA; NJEGA BEBE; OSVJEŽAVANJE; PAMUK; DONJI VEŠ; PERJE; SINTETIKA; SPORTSKA ODJEĆA; FARMERKE; OUTDOOR+	MJEŠOVITO, BRZO SUŠENJE, PAMUK, POSTELJINA, DJEČIJA ODJEĆA, PERJE, KOŠULJE, VUNA, DONJI VEŠ, PEŠKIRI, SPORTSKA ODJEĆA, SVILA, HLADAN ZRAK, VREMENSKO SUŠENJE
CERTIFIKATI	CB / CE / EMC / ROSH	CB / CE / EMC / ROSH	CB / CE / EMC / ROSH

FUEGO COMBO



NAZIV MODELA	WMDRFGTC 171416DD
KAPACITET	10 /7KG
ENERGETSKA EFIKASNOST	B
DIMENZIJE	595*628*850mm
NAZIVNA SNAGA	570W
BRZINA	1200RPM (0-400-800-1200)
TEMPERATURA	HLADNO-20-30-40-60-95°C
VOLUMEN UNUTRAŠNJEG	64L
TIP DISPLEJA	DODIR BOJE
MOTOR	DIREKTNI POGON
ODGODA	DA
NIVO BUKE	PRANJE 62dB CENTRIFUGA:76dB
NETO TEŽINA	71kg
PROGRAMI	MJEŠOVITO; SUPER BRZO; PAMUK; VUNA; INTENZIVNO; POSTELJINA; ANTIALERGIJSKI PROGRAM; PERJANA JAKNA; +PREDPRANJE; SAMO SUŠENJE; ZRAČNO PRANJE; ISPIRANJE+CENTRIFUGA; CENTRIFUGA; ČIŠĆENJE BUBNJA; CB / CE / EMC / ROSH
SRETIFIKATI	CB / CE / EMC / ROSH





HLADNJACI

MINI Fuego hladnjaci su dizajnirani da očuvaju svježinu uz optimiziran protok zraka, stabilne temperature i pametna rješenja za pohranu. Od kompaktnih modela s jednim vratima do velikih modela s više vrata, svaki uređaj je osmišljen za efikasnu organizaciju i nisku potrošnju energije. Ugradbeni modeli omogućavaju savršeno uklapanje u svaki enterijer, uz zadržavanje punog kapaciteta i performansi.



HLADNJACI

FUEGO REFS /MINI BAR



NAZIV MODELA	RFFGHOMB51SW	RFFGHOMB51SB
KAPACITET	41 Litara	41 Litara
DIMENZIJE	44 X 48 X 52cm	44 X 48 X 52cm
KAPACITET PUNJENJA 40HQ	599 PCS	599 PCS
SERTIFIKATI	CB / CE / EMC	CB / CE / EMC
	<ul style="list-style-type: none"> • MEHANIČKA KONTROLA • COOL ZONA • DRŽAČ ZA BOCE OD 2L • UGRADNA RUČKA • REVERSIBILNA VRATA 	<ul style="list-style-type: none"> • MEHANIČKA KONTROLA • COOL ZONA • DRŽAČ ZA BOCE OD 2L • UGRADNA RUČKA • REVERSIBILNA VRATA

FUEGO HLADNJACI / JEDNA VRATA



NAZIV MODELA	RFFGHOTT85SW	RFFGHOTT85SS
KAPACITET	90 Litara	90 Litara
DIMENZIJE	48 x 45 x 84cm	48 x 45 x 84cm
KAPACITET PUNJENJA 40HQ	356 PCS	356 PCS
SERTIFIKATI	CB / CE / EMC / ROSH	CB / CE / EMC / ROSH
	<ul style="list-style-type: none"> • MEHANIČKA KONTROLA • COOL ZONA • DRŽAČ ZA BOCE OD 2L • UGRADNA RUČKA • REVERZIBILNA VRATA 	<ul style="list-style-type: none"> • MEHANIČKA KONTROLA • COOL ZONA • DRŽAČ ZA BOCE OD 2L • UGRADNA RUČKA • REVERZIBILNA VRATA

FUEGO REFS / S JEDNIM VRATIMA



NAZIV MODELA	RFFGHOLA143SW	RFFGHOLA170SX	RFFGHOLA359FSX
KAPACITET	156 Litara	331 Litara	359 Litara
DIMENZIJE	55 x 58 x 143cm	60 x 59 x 173cm	60 x 59 x 173cm
SERTIFIKATI	CE / GS / CB / SAA	CE / GS / CB / SAA	CE / GS / CB / SAA
	<ul style="list-style-type: none"> • MEHANIČKA KONTROLA • ZONA HLAĐENJA • STAKLENE POLICE • UVUČENA RUČKA • REVERZIBILNA VRATA 	<ul style="list-style-type: none"> • MEHANIČKA KONTROLA • ZONA HLAĐENJA • STAKLENE POLICE • UVUČENA RUČKA • REVERZIBILNA VRATA 	<ul style="list-style-type: none"> • DISPENZER ZA VODU • TOTAL NO FROST • LED DODIRNI DISPLEJ • CLEAR SKY LED OSVJETLJENJE • REVERZIBILNA VRATA • POWER COOL • HOLIDAY NAČIN RADA

FUEGO REFS / GORNJI FRIŽIDER



NAZIV MODELA	FGTM217W	FGTM217X
KAPACITET	206 Litara	206 Litara
DIMENZIJE	55 x 56 x 143cm	55 x 56 x 143cm
ENERGETSKA EFIKASNOST	A+	A+
SERTIFIKATI	CE / GS / CB / SAA	CE / GS / CB / SAA
	<ul style="list-style-type: none"> • NETO KAPACITET FRIŽIDERA: 169L; NE • NETO KAPACITET ZAMRZIVAČA 37 L; • MEHANIČKA KONTROLA • REVERZIBILNA VRATA 	<ul style="list-style-type: none"> • NETO KAPACITET FRIŽIDERA: 169L; • NETO KAPACITET ZAMRZIVAČA 37 L; • MEHANIČKA KONTROLA • REVERZIBILNA VRATA





NAZIV MODELA	FGTF165W	FGTF165X
KAPACITET	248 Litara	248 Litara
DIMENZIJE	55 x 58 x 166cm	55 x 58 x 166cm
ENERGETSKA EFIKASNOST	A+	A+
SERTIFIKATI	CE / GS / CB / GCC / KC	CE / GS / CB / GCC / KC
	<ul style="list-style-type: none"> • NETO KAPACITET FRIŽIDERA: 198 L • NETO KAPACITET ZAMRZIVAČA: 50 L • MEHANIČKA KONTROLA • REVERZIBILNA VRATA 	<ul style="list-style-type: none"> • NETO KAPACITET FRIŽIDERA: 198 L • NETO KAPACITET ZAMRZIVAČA: 50 L • MEHANIČKA KONTROLA • REVERZIBILNA VRATA



NAZIV MODELA	FGTM5205WNF	FGTM5205XNF
KAPACITET	197 Litara	197 Litara
DIMENZIJE	55 x 56 x 143cm	55 x 56 x 143cm
ENERGETSKA EFIKASNOST	A+	A+
SERTIFIKATI	CE / GS / CB / SAA / GCC	CE / GS / CB / SAA / GCC
	<ul style="list-style-type: none"> • NETO KAPACITET FRIŽIDERA: 145 L • NETO KAPACITET ZAMRZIVAČA: 52 L • ELEKTRONSKO UPRAVLJANJE • REVERZIBILNA VRATA • TOTAL NO FROST • INTEGRISANI ZRAČNI KANAL 	<ul style="list-style-type: none"> • NETO KAPACITET FRIŽIDERA: 145 L • NETO KAPACITET ZAMRZIVAČA: 52 L • ELEKTRONSKO UPRAVLJANJE • REVERZIBILNA VRATA • TOTAL NO FROST • INTEGRISANI ZRAČNI KANAL



NAZIV MODELA	FGTM5252WNF	FGTM5252XNF
KAPACITET	247 Litara	247 Litara
DIMENZIJE	55 x 56 x 167cm	55 x 56 x 167cm
ENERGETSKA EFIKASNOST	A+	A+
SERTIFIKATI	CE / GS / CB / SAA / GCC	CE / GS / CB / SAA / GCC
	<ul style="list-style-type: none"> • NETO KAPACITET FRIŽIDERA: 195 L • NETO KAPACITET ZAMRZIVAČA: 52 L • ELEKTRONSKA KONTROLA • REVERZIBILNA VRATA (MOGU SE MONTIRATI DA SE OTVARAJU LIJEVO ILI DESNO) • TOTAL NO FROST • INTEGRISANI ZRAČNI KANAL 	<ul style="list-style-type: none"> • NETO KAPACITET FRIŽIDERA: 195 L • NETO KAPACITET ZAMRZIVAČA: 52 L • ELEKTRONSKO UPRAVLJANJE • REVERZIBILNA VRATA • TOTAL NO FROST (BEZ STVARANJA LEDA) • INTEGRISANI ZRAČNI KANAL



NAZIV MODELA	RFFGHODD415NFBG
KAPACITET	415 Litara
DIMENZIJE	71 x 69 x 178cm
ENERGETSKA EFIKASNOST	A+
SERTIFIKATI	CE / GS / CB / SAA / GCC
	<ul style="list-style-type: none"> • NETO KAPACITET FRIŽIDERA: 321 L • NETO KAPACITET ZAMRZIVAČA: 94 L • ELEKTRONSKO UPRAVLJANJE • REVERZIBILNA VRATA • TOTAL NO FROST (BEZ STVARANJA LEDA) • INTEGRISANI ZRAČNI KANAL • LED DODIRNI (TOUCH) DISPLEJ

FUEGO REFS / DONJI ZAMRZIVAČ



NAZIV MODELA	FGBM55180W / BJELA	FGBF185WH / BJELA
	FGBM55180X / INOKS	FGBF185XH / INOKS
KAPACITET	262 Litara	315 Litara
DIMENZIJE	55 x 56 x 180cm	60 x 60 x 186cm
ENERGETSKA EFIKASNOST	A+	A+
SERTIFIKATI	CE / GS / CB / SAA / GCC	CE / GS / CB / SAA / GCC
	<ul style="list-style-type: none"> • NETO KAPACITET FRIŽIDERA: 191 L • NETO KAPACITET ZAMRZIVAČA: 71 L • REVERZIBILNA VRATA • POLICA NA VRATIMA 	<ul style="list-style-type: none"> • NETO KAPACITET FRIŽIDERA: 219 L • NETO KAPACITET ZAMRZIVAČA: 96 L • ELEKTRONSKO UPRAVLJANJE • REVERZIBILNA VRATA • POLICA NA VRATIMA



NAZIV MODELA	RFFGHOB286NFB	RFFGHOB400NFB CRNI RFFGHOB400NFI- INOKS
KAPACITET	286 Litara	400 Litara
ENERGETSKA EFIKASNOST	A+	A+
DIMENZIJE	60 x 60 x 186cm	60 x 68 x 186cm
SERTIFIKATI	CE / GS / CB / SAA / GCC	CE / GS / CB / SAA / GCC
	<ul style="list-style-type: none"> • NETO KAPACITET FRIŽIDERA: 210 L • NETO KAPACITET ZAMRZIVAČA: 76 L • TOTAL NO FROST (BEZ STVARANJA LEDA) • ELEKTRONSKO UPRAVLJANJE • REVERZIBILNA VRATA 	<ul style="list-style-type: none"> • NETO KAPACITET FRIŽIDERA: 273 L • NETO KAPACITET ZAMRZIVAČA: 127 L • TOTAL NO FROST (BEZ STVARANJA LEDA) • ELEKTRONSKO UPRAVLJANJE • REVERZIBILNA VRATA



NAZIV MODELA	RFFGHOB286NFW / BJELA	RFFGHOB286NFB / CRNI
	RFFGHOB286NFX / INOKS	RFFGHOB286NFX / INOKS
KAPACITET	286 Litara	286 Litara
DIMENZIJE	60 x 60 x 186cm	60 x 60 x 186cm
ENERGETSKA EFIKASNOST	A+	A+
SERTIFIKATI	CE / GS / CB / SAA / GCC	CE / GS / CB / SAA / GCC
	<ul style="list-style-type: none"> • NETO KAPACITET FRIŽIDERA: 210 L • NETO KAPACITET ZAMRZIVAČA: 76 L • REVERZIBILNA VRATA • POLICA NA VRATIMA (DOOR BALCONY) • TOTAL NO FROST (BEZ STVARANJA LEDA) 	<ul style="list-style-type: none"> • NETO KAPACITET FRIŽIDERA: 210 L • NETO KAPACITET ZAMRZIVAČA: 76 L • ELEKTRONSKO UPRAVLJANJE • REVERZIBILNA VRATA • POLICA NA VRATIMA (DOOR BALCONY) • TOTAL NO FROST (BEZ STVARANJA LEDA)

FUEGO REFS / SBS



NAZIV MODELA	FGSBS 9059X	RFFGHOSBS 436WDBG
KAPACITET	436 Litara	436 Litara
ENERGETSKA EFIKASNOST	A+	A+
DIMENZIJE	91 x 59 x 177cm	90 x 73 x 177cm
SERTIFIKATI	CE / GS / CB / SAA / GCC	CE / GS / CB / SAA / GCC
	<ul style="list-style-type: none"> • TOTAL NO FROST • ELEKTRONSKO UPRAVLJANJE 	<ul style="list-style-type: none"> • TOTAL NO FROST (BEZ STVARANJA LEDA) • ELEKTRONSKO UPRAVLJANJE • LED DODIRNI (TOUCH) DISPLEJ • PAMETNA KONVERTIBILNA LADICA • METAL COOLING (METALNO HLADENJE)

FUEGO REFS / S VIŠE VRATA



NAZIV MODELA	RFFGHOMD337BG / CRNI RFFGHO337MDX / INOKS	RFFGHOMD503DX	RFFGHO522MDX
KAPACITET	337 Litara	503 Litara	522 Litara
ENERGETSKA EFIKASNOST	A+	A+	A+
DIMENZIJE	79 x 62 x 180cm	90 x 60 x 190cm	90 x 60 x 190cm
SERTIFIKATI	CE / GS / CB / SAA / GCC	CE / GS / CB / SAA / GCC	CE/GS/CB/SAA/GCC
	<ul style="list-style-type: none"> • TOTAL NO FROST • ELEKTRONSKO UPRAVLJANJE • LED DODIRNI (TOUCH) DISPLEJ • 360° MULTI-AIR FLOW (VIŠESMJERNO KRUŽENJE ZRAKA) • PAMETNA KONVERTIBILNA LADICA • METAL COOLING – OPCIONALNO 	<ul style="list-style-type: none"> • TOTAL NO FROST • ELEKTRONSKO UPRAVLJANJE • LED DODIRNI (TOUCH) DISPLEJ • TRIPLE INVERTER AG+ • PAMETNA KONVERTIBILNA LADICA • METAL COOLING (METALNO HLAĐENJE) 	<ul style="list-style-type: none"> • TOTAL NO FROST • ELEKTRONSKO UPRAVLJANJE • LED DODIRNI (TOUCH) DISPLEJ • DUAL INVERTER • PAMETNA KONVERTIBILNA LADICA • METAL COOLING (METALNO HLAĐENJE)

FUEGO REFS / UGRADBENI



NAZIV MODELA	RFFGHOSD 130BI	FGBIBM 5259W	RFFGHOBİ 253NF
KAPACITET	129 Litara	248 Litara	242 Litara
ENERGETSKA EFIKASNOST	A+	A+	A+
DIMENZIJE	54 x 54 x 89cm	54 x 54 x 178.5cm	54 x 54 x 178.5cm
SERTIFIKATI	CE / GS / CB / SAA / GCC	CE / GS / CB / SAA / GCC	CE / GS/CB/SAA/GCC
	<ul style="list-style-type: none"> • TABLE TOP (STOLNI) FRIŽIDER S • REVERZIBILNIM VRATIMA • MEHANIČKO UPRAVLJANJE 	<ul style="list-style-type: none"> • POLICA NA VRATIMA 	<ul style="list-style-type: none"> • TOTAL NO FROST • REVERZIBILNA VRATA • (DVOSTRUKI SISTEM HLAĐENJA) • LED DODIRNI (TOUCH) DISPLEJ • FRESH ZONE (ZONA SVJEŽINE) • ALARM ZA OTVORENA VRATA • BRZO ZAMRZAVANJE • UKLJUČIVANJE/ISKLJUČIVANJE NAPAJANJA





FUEGO REFS / USPRAVNI FRIZIDERI



NAZIV MODELA	RFFGHOUF 143SW	RFFGHOUF 200NFX	RFFGHOUF 100MC
KAPACITET	157 Litara	204 Litara	87 Litara
ENERGETSKA EFIKASNOST	A+	A+	A
DIMENZIJE	55 x 58 x 142cm	54 x 60 x 170cm	55 x 58 x 85cm
SERTIFIKATI	CE / GS / CB / SAA / GCC	CE / GS / CB / SAA / GCC	CE / GS/CB/SAA/GCC
		<ul style="list-style-type: none"> • BEZ STVARANJA LEDA • UVUČENA RUČKA 	<ul style="list-style-type: none"> • 3 FIOKE

FUEGO REFS / SANDUK ZAMRZIVAČI



NAZIV MODELA	KAPACITET	DIMENZIJE
CFFGHO 500MC	500L	/
FGHO380CFMC	380L MEHANIČKI	130 x 70 x 85cm
FGHO290CFMC	290L MEHANIČKI	109 x 61 x 85cm
FGHO251CFMC	251L MEHANIČKI	95 x 62 x 85cm
FGCF9200W	200L MEHANIČKI	91 x 55 x 85cm
FGCF7150W	145L MEHANIČKI	71 x 55 x 85cm
FGHO98CFMC	98L MEHANIČKI	55 x 48 x 85cm



NAZIV MODELA	KAPACITET	DIMENZIJE
FGHO251CFEC	251L MEHANIČKI	95 x 62 x 85cm
FGHO145CFEC	145L MEHANIČKI	71 x 55 x 85cm
FGHO98CFEC	98L MEHANIČKI	55 x 48 x 85cm



fuego-international.com

info@fuego-international.com

